

GROSS LOAD CAPACITY WHEN USED AS A WEIGHT CARRYING HITCH: 3,500 LBS. TRAILER WEIGHT & 350 LBS. TONGUE WEIGHT.
*****DO NOT EXCEED VEHICLE MANUFACTURER'S RECOMMENDED TOWING CAPACITY.*****

Parts List			
ITEM	QTY	PART NUMBER	DESCRIPTION
1	1	1_2 FISHWIRE	1/2" FISHWIRE
2	6	10-10287	BOLT,CAR,1/2-13 UNC,1-1/2,GRD8,YZ
3	6	CM-SP40	.188 x 1.00 x 3.00" SQUARE HOLE SPACER
4	6	20-00062	NUT, SER-FLANGE,1/2-13 UNC,GRD8,YZ

REVERSE PULL FISHWIRE TECHNIQUE

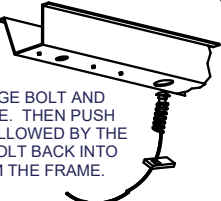

TO FISHWIRE CENTER HOLE, ATTACH FISHWIRE TO CARRIAGE BOLT AND SLIDE SPACER ONTO FISHWIRE. THEN PUSH THE BOLT THRU THE HOLE FOLLOWED BY THE SPACER (AS SHOWN). PULL BOLT BACK INTO POSITION, PROTRUDING FROM THE FRAME.

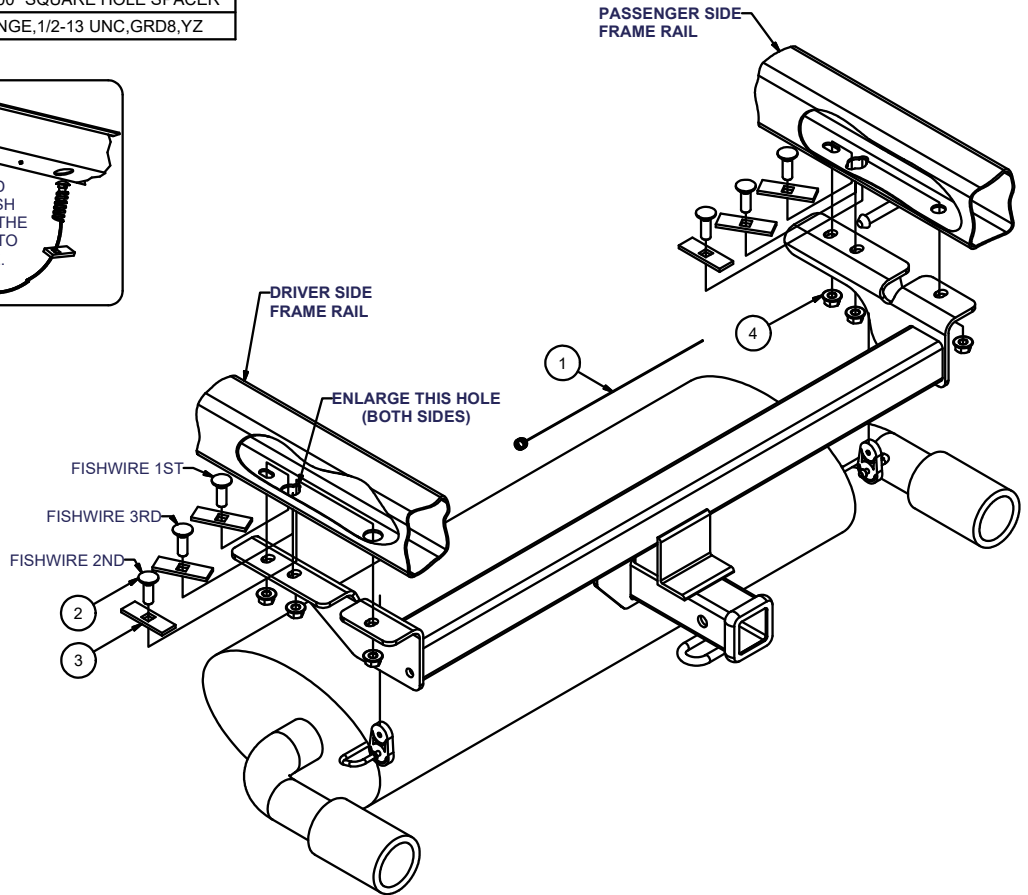
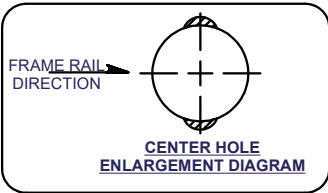

HITCH WEIGHT: 36 LBS.
 INSTALL TIME: 30 MINUTES

INSTALL NOTES:
 - LOWER EXHAUST
 - ENLARGE HOLES (2)
 - FISHWIRING REQUIRED

INSTALLATION STEPS

- 1) Lower (4) muffer exhaust hangers (recommend sliding rubber hanger off chassis side).
- 2) Enlarge center hole (enough to allow spacer and carriage bolts to pass through), on both sides as shown in diagram above.
- 3) Fishwire all carriage bolts and spacers into position (fishwire forward and aft fasteners first, then use reverse pull method for center hole as shown above).
- 4) Raise hitch into position and attach using supplied 1/2" hex flange nuts.
- 5) Torque all 1/2" fasteners to 110 lb-ft.
- 6) Re-install exhaust into original position.

PERIODICALLY CHECK THIS RECEIVER HITCH TO ENSURE THAT ALL FASTENERS ARE TIGHT AND THAT ALL STRUCTURAL COMPONENTS ARE SOUND.

Curt Manufacturing Inc., warrants this product to be free of defects in material and/or workmanship at the time of retail purchase by the original purchaser. If the product is found to be defective, Curt Manufacturing Inc., may repair or replace the product, at their option, when the product is returned, prepaid, with proof of purchase. Alteration to, misuse of, or improper installation of this product voids the warranty. Curt Manufacturing Inc.'s liability is limited to repair or replacement of products found to be defective, and specifically excludes liability for incidental or consequential loss or damage.